

PBOB – Plexon Breakout Box

Figure 1 - PBOB Functional Diagram

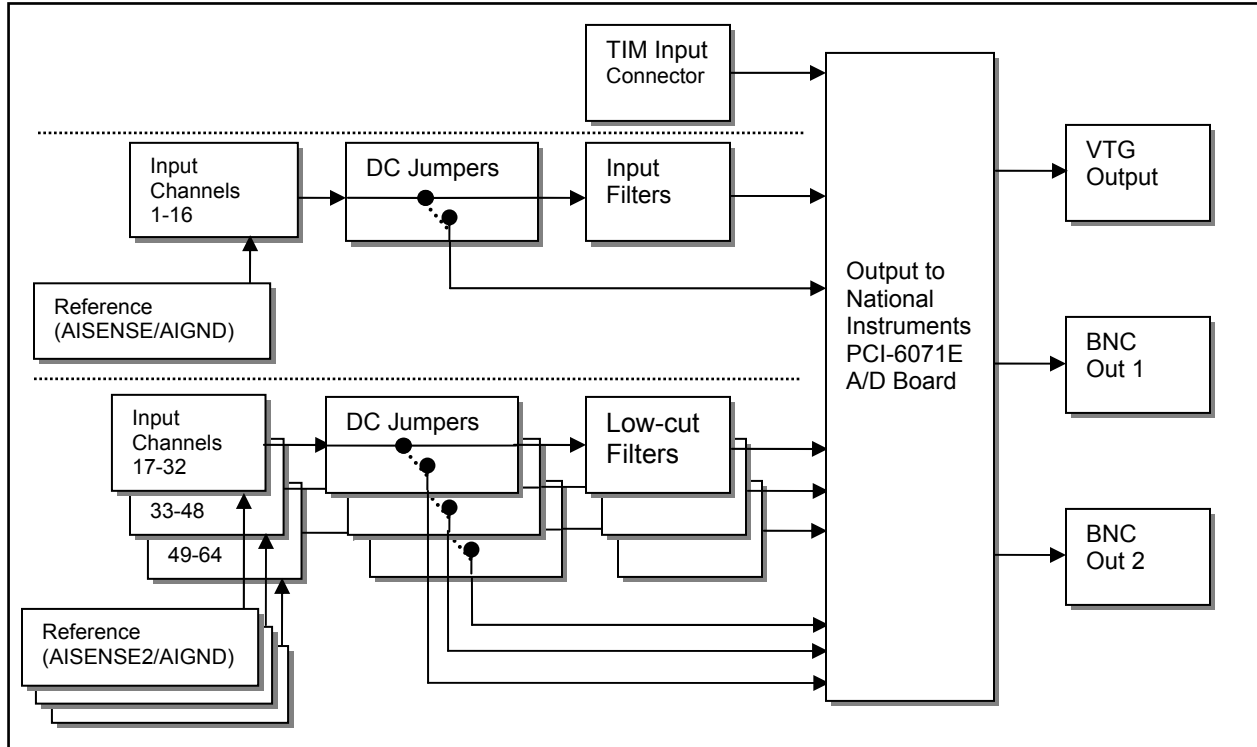

Description

The Plexon Breakout Box (PBOB) is an interface to the National Instruments PCI-6071E A/D board which provides 64 channels of analog to digital conversion. Physically, the PBOB provides access to the 64 channels through four 16-channel connectors. Functionally, however, the 64 channels of the PCI-6071E are divided into two groups. The first group consists of channels 1-16 and the second group consists of channels 17-64. When the PCI-6071E is configured in the non-referenced single ended (NRSE) configuration, as recommended by Plexon, the output of each channel is the amplified difference between the channel input and a common reference input called AISENSE or AISENSE2. AISENSE is the common reference input for channels 1-16 and AISENSE2 is the common reference input for channels 17-64. This differential recording between the channel input and the AISENSE input helps remove common mode noise and ground fluctuations from the recorded signal. Figure 1 shows the functional block diagram of the PBOB.

Example: The output of channel 3 is the amplified difference between the input to channel 3 and the input to AISENSE.

Example 2: The output of channel 43 is the amplified difference between the input to channel 43 and the input to AISENSE2.

Reference Jumpers

For each 16 channel input connector there is a jumper that allows you to choose whether or not to use the differential reference input for those channels. In most cases the reference input should be used to take advantage of the noise rejection it provides. The jumper for channels 1-16 should be placed in the AISENSE position (no jumper at all, see Figure 2) and the jumpers for channels 17-32, 33-48, and 49-64 should be placed in the AISENSE2 position. The only time you may want to disconnect one or more input connectors from the reference input is when you have more than two signal sources and you are forced to connect two different sources to the same group of PBOB inputs. In this case you may want to disconnect the source with the highest amplitude signals from the reference input (see Figure 7).

Optional Low-cut Filters & DC Couple Jumpers

The PBOB provides an optional low cut filter (0.7 Hz, 1 pole) for each input channel. The low cut filter will remove a constant "DC" level from the input signal before it is further amplified by the NIDAQ board. For each channel, a "DC couple" jumper may be applied to bypass the low-cut filter and allow the constant "DC" level of the input signal through.

The PBOB low cut filter is used primarily with older Plexon field potential preamplifiers with 500x gain and 1-pole filtering. These pre-amplifiers had a non-negligible amount of DC offset present in their output signals. Newer Plexon field potential preamps, with gain of 1000x and multi pole filters, have very little offset and do not require the optional low cut filter.

For some signal sources, such as eye position trackers, the DC level of the signal has important information. The optional low cut filters should be bypassed when using these types of devices.

Typically, each input connector will have the same configuration for all of its jumpers (All 16 jumpers will be ON or all 16 jumpers will be OFF) but may have different jumper configurations than the other input connectors (see page 4)

Layout Diagram

Figure 2 - PBOB Layout Diagram

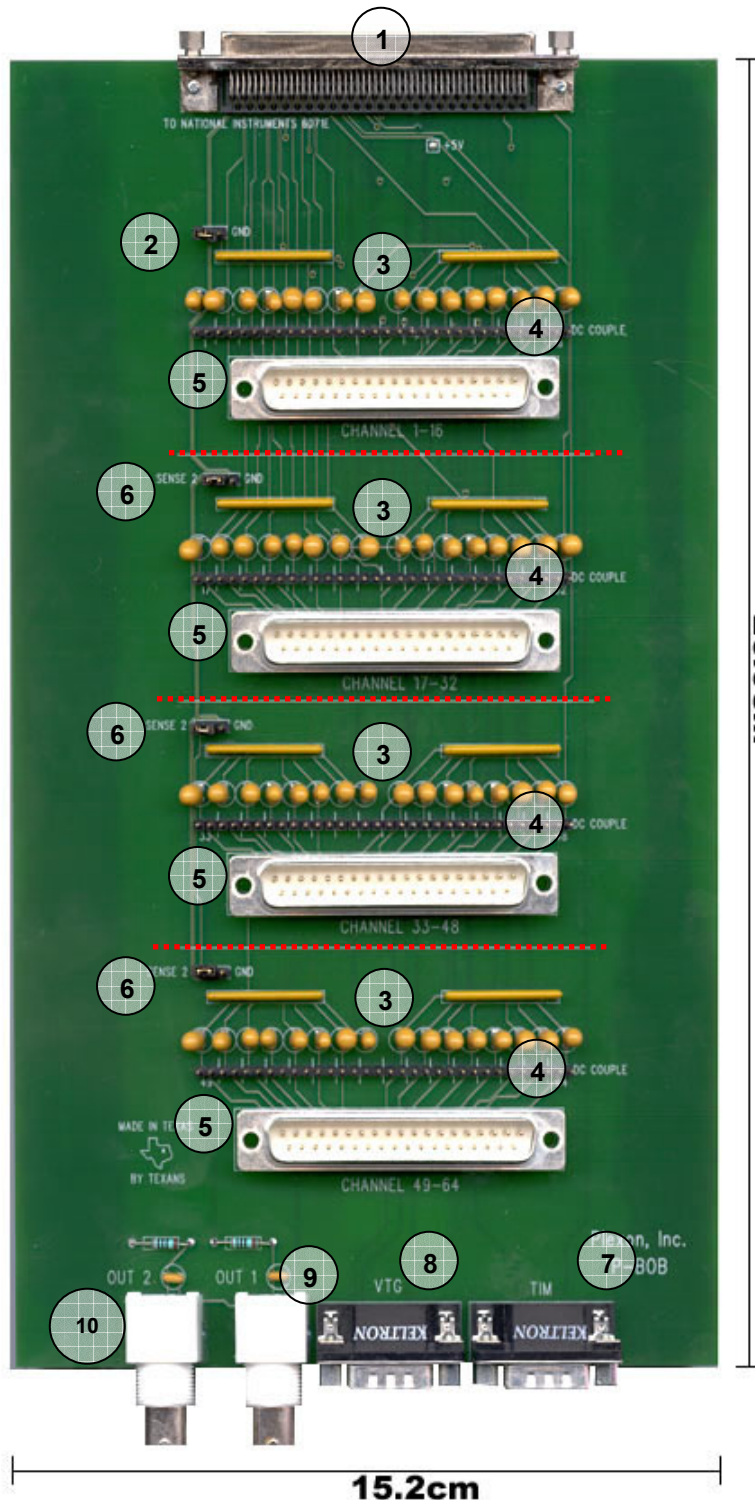

1	<p>Output Connector To NIDAQ PCI 6071E 64 channels 12-bit resolution</p>
2	<p>Reference Jumper AIGND – ON AISENSE – OFF</p>
3	<p>Optional Low-cut Filter (0.7 Hz cutoff, 1-pole)</p>
4	<p>Filter Bypass / DC Couple Jumpers Bypass Filter - ON Use Filter - OFF</p>
5	<p>Input Connector 4 connectors/board Each input 16 channels DB 37 connector Input circuits separated by red dotted lines</p>
6	<p>Reference Jumper AIGND –RIGHT AISENSE2 – LEFT</p>
7	<p>TIM Connector MAP – connect to TIM Recorder – not used</p>
8	<p>VTG Connector Only used with Neurosurgery workstation</p>
9	<p>BNC Out 1 MAP – not used Recorder – active channel</p>
10	<p>BNC Out 2 Not used</p>

Output to National Instruments PCI 6071E A/D Board

The National Instruments PCI 6071E Output is a 100-pin connector that connects to the National Instruments PCI-6071E A/D board. This output is the primary output of the PBOB.

TIM Input

The TIM Input Connector is a male DB9 connector that can be used to bring external timing signals to the PCI-6071E A/D board. When used in conjunction with a MAP system, the TIM Input Connector receives a clock and a start signal from the MAP. These signals ensure that the continuous data acquired by the A/D board is synchronized with the spike data recorded by the MAP box. The TIM Input Connector is not used with Recorder systems.

VTG Output

The VTG output is a DB9 connector that is only used with the Neurosurgery workstation.

BNC Out 1

BNC Out 1 is a BNC output that has the active channel present when using the recorder software. BNC Out 1 is not used with a MAP system.

BNC Out 2

BNC Out 2 is a BNC output that is currently not used.

Low-cut Filter Bypass / DC Couple Jumpers

For each input connector, there is a jumper block that contains one filter bypass jumper for each channel. Each DC Couple Jumper block consists of 32 pins with each adjacent pair of pins corresponding to channels 1-16 of the corresponding input connector. Figure 3 shows how each pair of pins relates to the input channels – the channel number increases from left to right. Depending on the input connector the actual channel numbers may be 1-16 (top input connector), 17-32 (2nd from top input connector), 33-48 (2nd from bottom input connector), or 49-64 (bottom input connector).

Typically, all of the jumper settings on a particular block will be the same – all jumpers ON or all jumpers OFF. The configuration depends on the source of the input channels. For example, when using older preamps the jumpers would be left OFF, and the filters would be used. When using the newer preamps, filtering is not needed on the PBOB. Thus, the jumpers would be ON.

Figure 3 – DC Couple Channel numbering

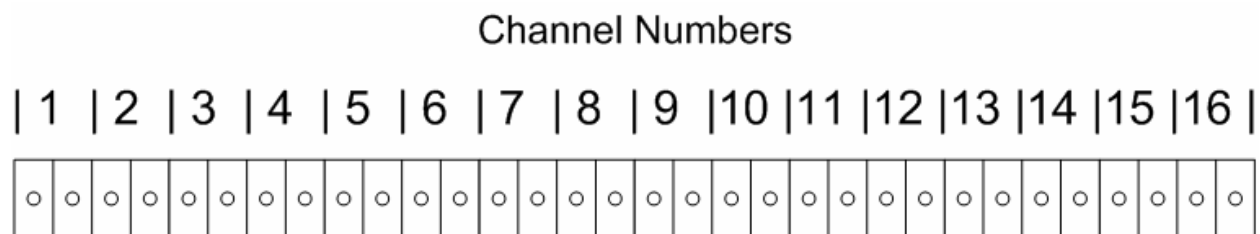

Input Connector Information

Each of the four Input Connectors on the PBOB can receive 16 channels of information. The connectors have 37 pins (DB37) of which only 32 pins are used. 16 of the pins are the 16 channel inputs and 16 of the pins are a common reference input. Pins 17-19, 36, and 37 are not used. The reference input is either AISENSE or AIGND for channels 1-16 and either AISENSE2 or AIGND for channels 17-64 depending on the reference jumper configuration. Figure 4 shows the pin configuration of the input connector. The reference levels are identified as SENSE/GND to keep the diagram generic.

Figure 4 - Input Connector Pinout Diagram

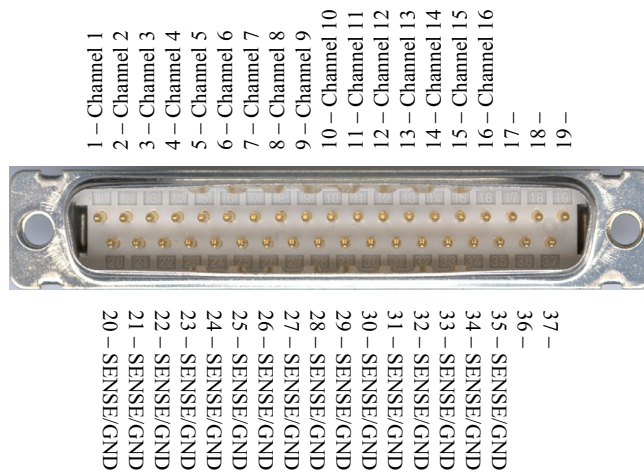

Connecting Signals to the PBOB

The PBOB was designed primarily to connect to Plexon field potential preamplifiers with 16 to 64 output channels but may be used with a wide variety of signal sources. Before connecting multiple signal sources to the PBOB, it is necessary to consider the number of signal sources and the number of outputs coming from each source. The goal is to keep the signals from each source isolated from each other and to take advantage of the common mode noise rejection provided by the AISENSE and AISENSE2 inputs whenever possible. For example, sources of more than 16 signals should be connected to the second group of inputs (channels 17-64) since the first group can only accommodate 16 channels. When there are more than two distinct signal sources it is not possible to have a distinct reference input for each source. In this case you should consider the type and amplitude of the signal source before deciding how to connect the sources. For sources with low amplitude signals, you want to take advantage of the common mode noise rejection provided by having a reference input. Digital (“TTL”) signals or large amplitude signals may not require this noise rejection. The examples on the following pages illustrate these ideas.

Feel free to contact Plexon if you have questions about connecting more than two sources to the PBOB.

Caution: All signal sources should be ground referenced, not “floating”. If you have a “floating” signal source such as a battery powered device please contact Plexon for assistance in connecting it to the PBOB.

Examples of Input Connector Configurations

Example 1 (Two Sources)

The primary signal source is a 16 channel pre-amplifier. The second source has up to 16 channels. The BNC-16 panel provides a convenient mechanism from bringing signals to the PBOB from sources with standard bayonet nut connectors (BNCs).

Connect the primary source to the first group of PBOB inputs, channels 1-16. The reference jumper for channels 1-16 should be placed in the AISENSE position (no jumper).

Connect the secondary signal source to the second group of channels, channels 17-32. The reference jumper for channels 17-32 should be set to AISENSE2.

Figure 5 - Example Configuration #1: 16 field potential channels from preamp box and 16 external channels from BNC/16 panel

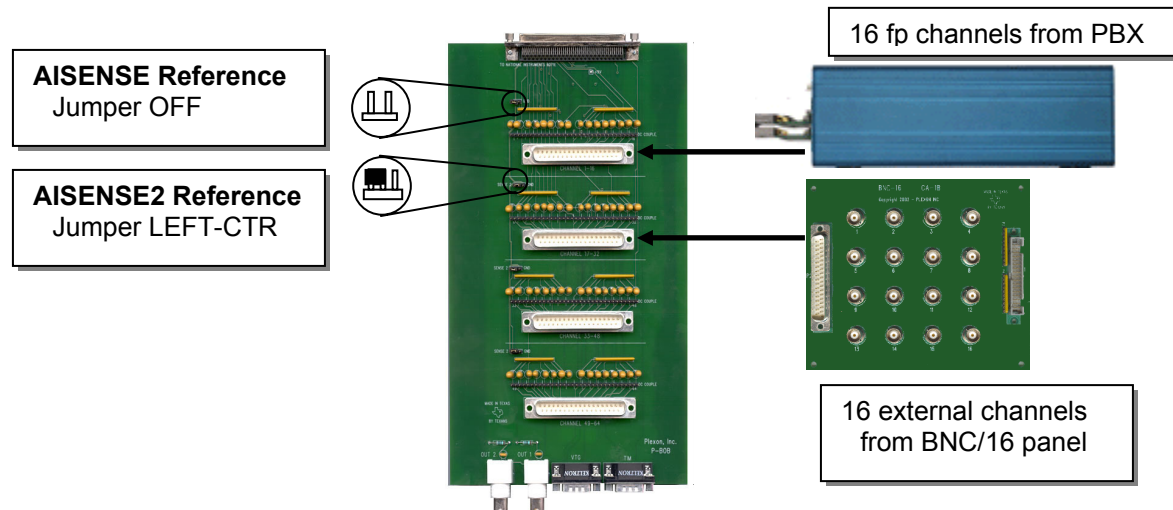

Example 2 (Two Sources)

The primary signal source is a 32 channel pre-amplifier. The second source has up to 16 channels.

Connect the primary source to the second group of PBOB inputs, channels 17-48. The reference jumper for channels 17-32 and for channels 33-48 should be set to AISENSE2.

Connect the second signal source to the first group of PBOB inputs, channels 1-16. The reference jumper for channels 1-16 should be placed in the AISENSE position.

Figure 6 - Example Configuration #2: 32 field potential channels from preamp box and 16 external channels from BNC/16 panel

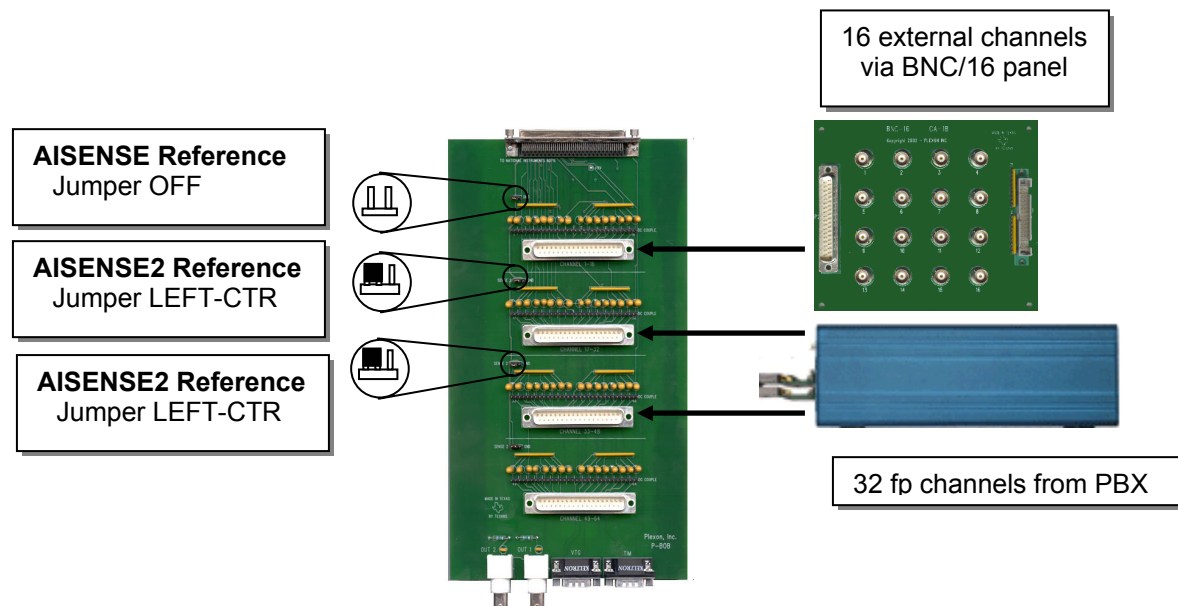

Example 3 (Three Sources)

The primary source is a 32 channel pre-amplifier. The second source has up to 16 channels and has low amplitude signals. The third source has up to 16 channels and has large amplitude signals.

Connect the primary signal source to the second group of PBOB inputs, channels 17-64. In the example it is connected to channels 33-64. The reference jumper for channels 33-48 and 49-64 should be set to the AISENSE2 position.

Connect the second signal source, with low amplitude signals, to the first group of PBOB channels (1-16) to take advantage of the reference input AISENSE. The reference jumper for channels 1-16 should be set to the AISENSE position.

Connect the third signal source to the remaining channels in group 2, channels 17-32. To prevent ground noise from this source from coupling onto the other channels of group2, set the reference jumper for channels 17-32 to the AIGND position (or remove the jumper completely)

Figure 7 - Example Configuration #3: 32 field potential channels from preamp box, 16 large amp channels from BNC/16 panel, and 16 small amp channels from BNC/16 panel

